

ENSAMBLADA

Modular Industry

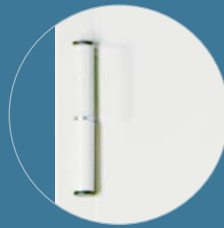
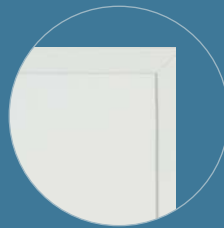

The Ensamblada door owes its name to the manufacturing system developed by Andreu and patented in 1974.

Later on, this design, based on a new welding free door assembly technique, was adopted by the steel door market and is now widely used in the sector.

The quality of the finishes and the variety of dimensions are characteristics that define the Andreu Ensamblada door.

Technical Characteristics

Single Leaf General Information

CROSS-SECTION A-A'

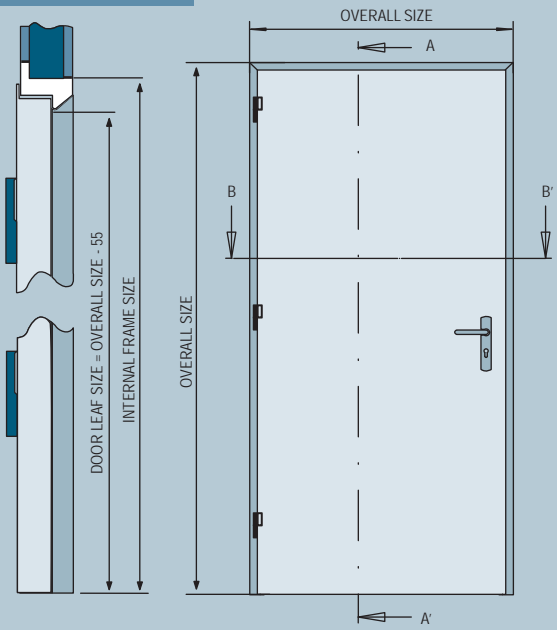

CROSS-SECTION B-B'

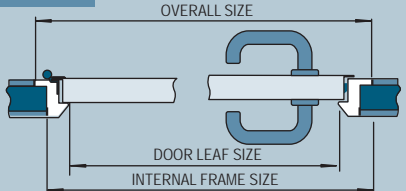

The **structure** consists of two 0.5-mm-thick galvanised steel sheets assembled without welding.

Its **interior** is composed of a chamber filled with high-pressure injected ecological material, providing high mechanical, thermal and acoustic resistance. The door is 38 mm thick.

The door is equipped with a minimum of **two** 2.5 mm thick **hinges**, manufactured in-house, screwed onto the leaf and soldered onto the frame.

The locking system includes a mortice **lock** with one-point locking system and a 30 x 30 brass cylinder with keys.

The **handle system** included in the standard range comprises two lever handles, two cover-plates with key-holes on both sides made of a highly-resistant material.

The door includes **corner brackets** reinforcements to ensure the rigidity of the leaf and frame and maintain the position of the door during installation.

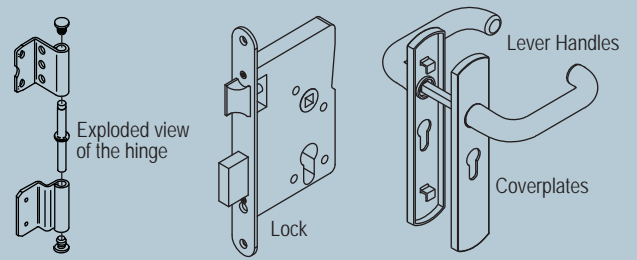

Standard Measurements Single Leaf

Model	Door Leaf size		Overall Size		Internal Frame Size	
	Width	Height	Width	Height	Width	Height
1L 600 CS4	600	1945	710	2000	670	1980
		2045		2100		2080
1L 700 CS4	700	1445	810	1500	770	1480
		1745		1800		1780
		1945		2000		1980
		2045		2100		2080
1L 800 CS4	800	1945	910	2000	870	1980
		2045		2100		2080
1L 900 CS4	900	1945	1010	2000	970	1980
		2045		2100		2080
1L 1000 CS4	1000	1945	1110	2000	1070	1980
		2045		2100		2080
1L 1100 CS4	1100	1945	1210	2000	1170	1980
		2045		2100		2080

Dimensions in millimetres.
Other measurements upon request.

There are 2 different standard frames for the Ensamblada doorset: the corner frame CS4 with 1 mm steel thickness and the double rebated frame C70 with 1,2 mm steel thickness.

The frames are screwed together, without any welding. Both frames have at least 3 steel anchors in the sides for the installation into the brickwork.

To keep the distance between the frame and the leave during the installation of the doorset; the Ensamblada door has a black corner bracket, a lower bar in the bottom and a central divider in the carter latch protection. All these items needs to be retired after installation.

CS4 Frame

- Corner frame
- 1 mm-thick galvanised steel
- Wide frame : can be adapted to any wall width.

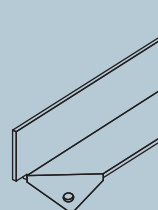
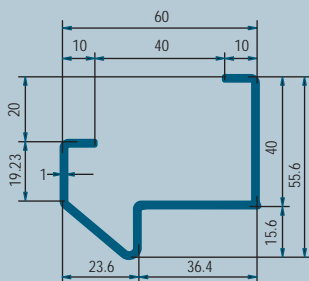

Lower bar CS4

Standard Finishings



Plain

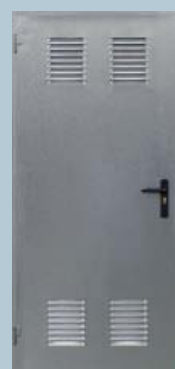

With Louvres



2L Plain

Double Leaf General Information

CROSS-SECTION A-A'

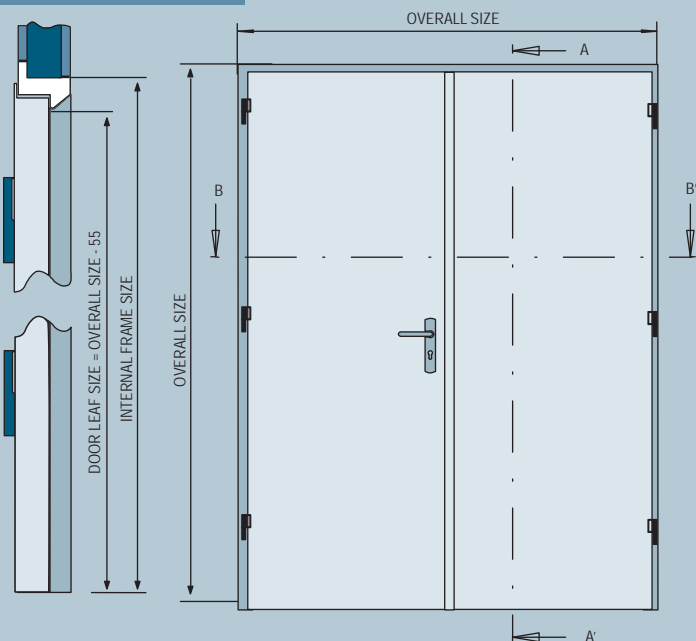

The **active leaf** has the same characteristics as the single leaf Ensamblada multipurpose door.

The **inactive leaf** has the same internal characteristics except for the flush bolt closing mechanism.

The double leaf Ensamblada door can be made with an asymmetric leaf i.e. the width of the active leaf differs from that of the inactive leaf. It can be manufactured in CS4, plain or ventilated door.

CROSS-SECTION B-B'

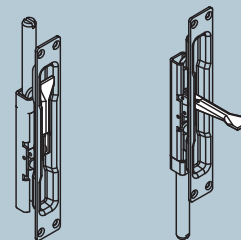
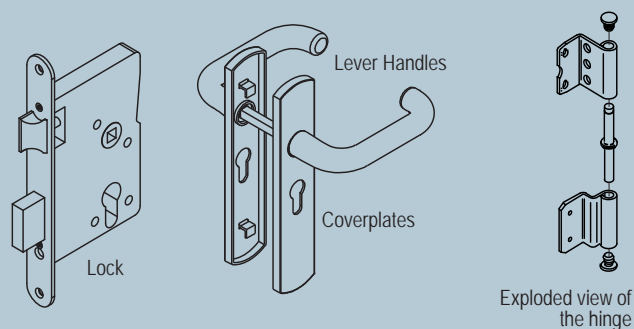
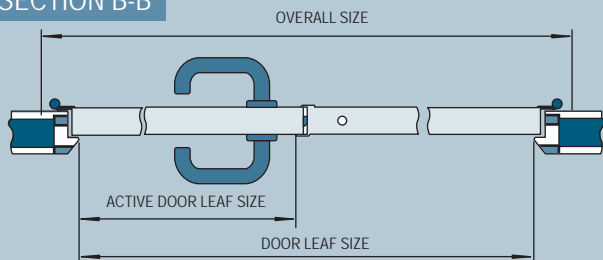

Flush bolt

Standard Measurements

Model	Door Leaf size		Overall Size			Internal Frame Size	
	Double Door Leaf Size	Active Door Leaf Size	Height	Width	Height	Width	Width
2L 1440 CS4	1440	698	1945	1550	2000	1510	1980
	1440	698	2045	1550	2100	1510	2080
2L 1640 CS4	1640	698	1945	1750	2000	1610	1980
	1640	698	2045	1750	2100	1610	2080
2L 1840 CS4	1840	698	1945	1950	2000	1910	1980
	1840	698	2045	1950	2100	1910	2080

Dimensions in millimetres.
Other measurements upon request.

Door Opening

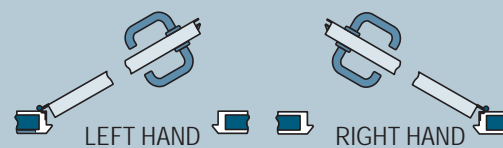

Louvers



2L With Louvres

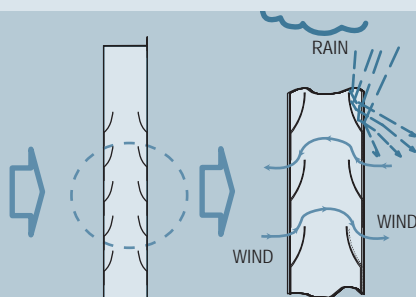

The Ensamblada door with louvres prevents water infiltration and allows airflow in any room. The door is manufactured with standard louvers sizes but the option of alternative sizes are available upon request.

Finishes



*Finishes are approximate due to printing results.
Other finishes available upon request.

Options

Counter Frame

COUNTER FRAME for 40 to 80 mm width sandwich panel

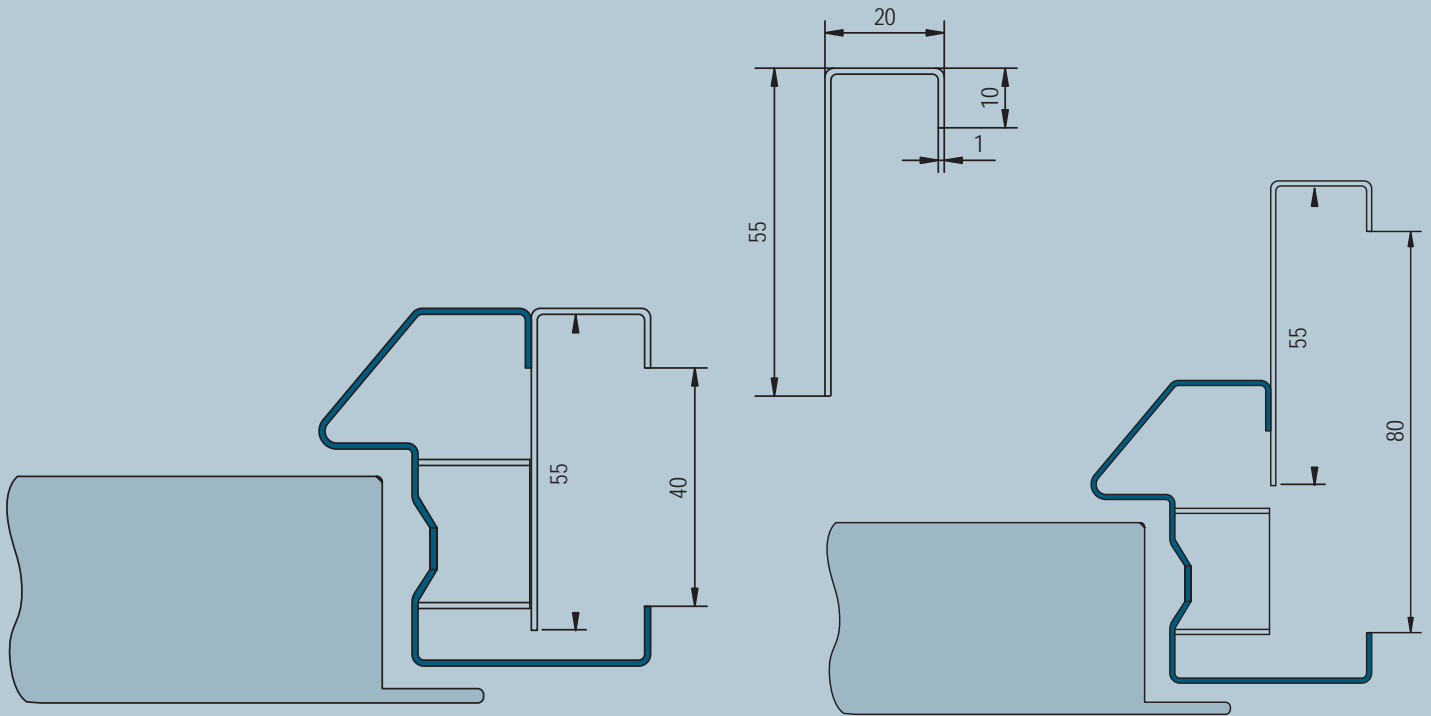

* Example of a CS4 frame with screwing system type B

COUNTER FRAME for 80 to 110 mm width sandwich panel

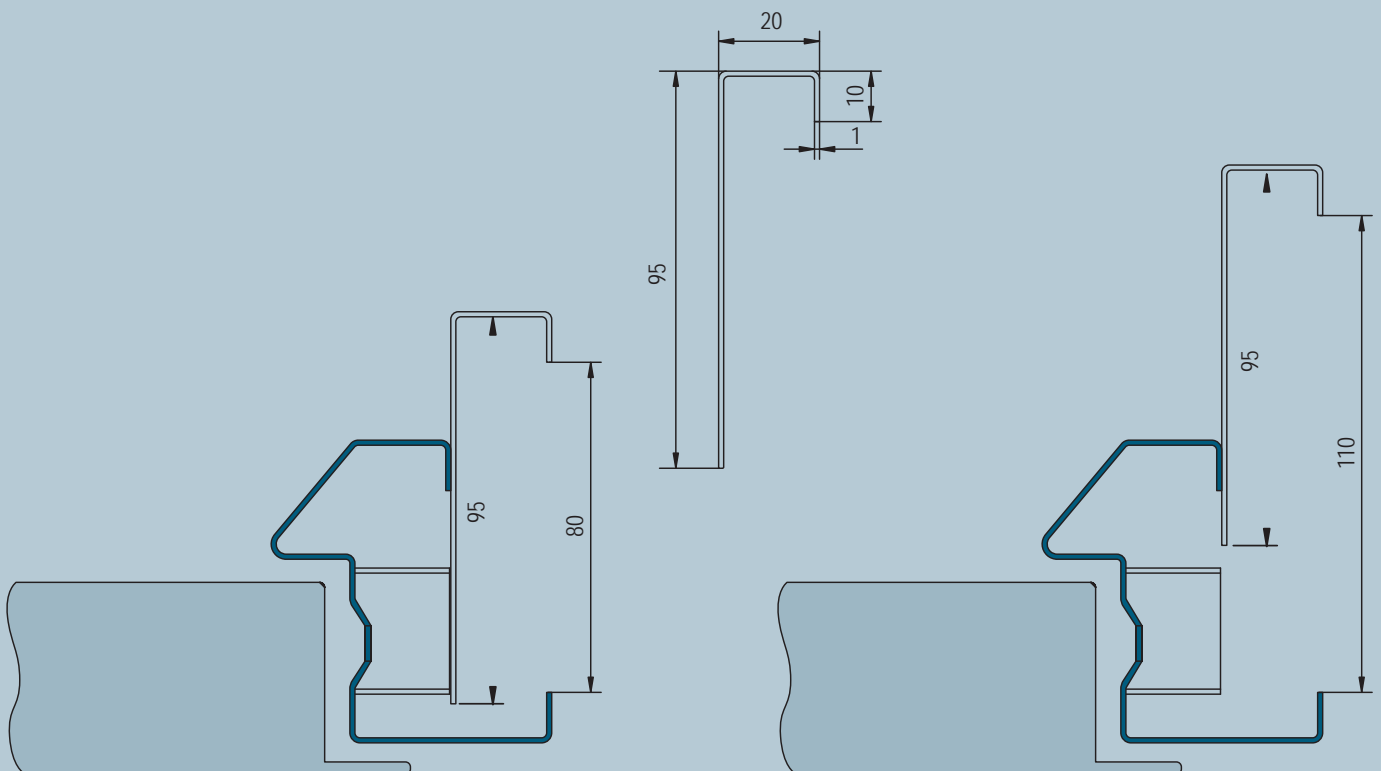

* Example of a CS4 frame with screwing system type B

Thresholds

Threshold Type A

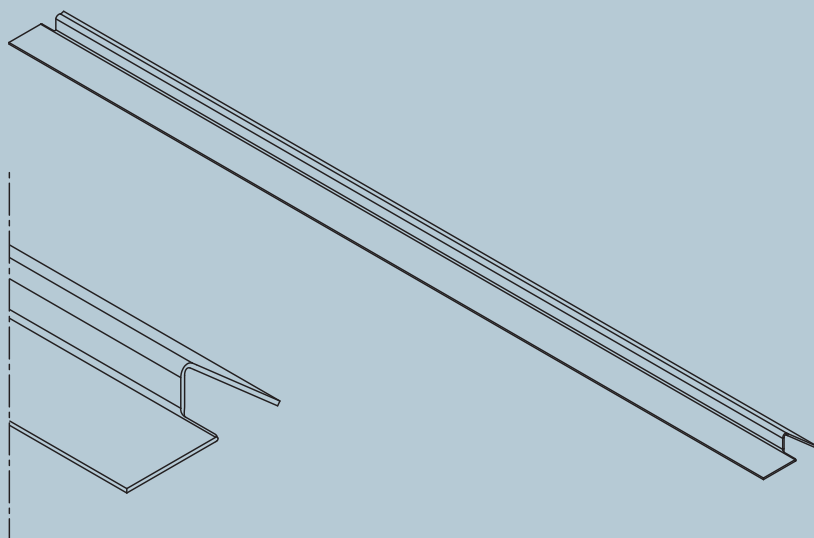
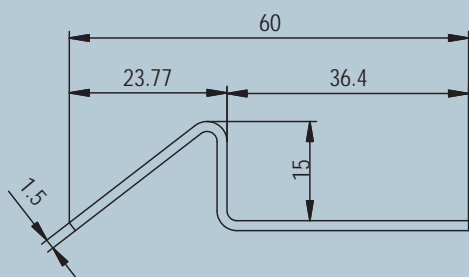

Threshold Type B

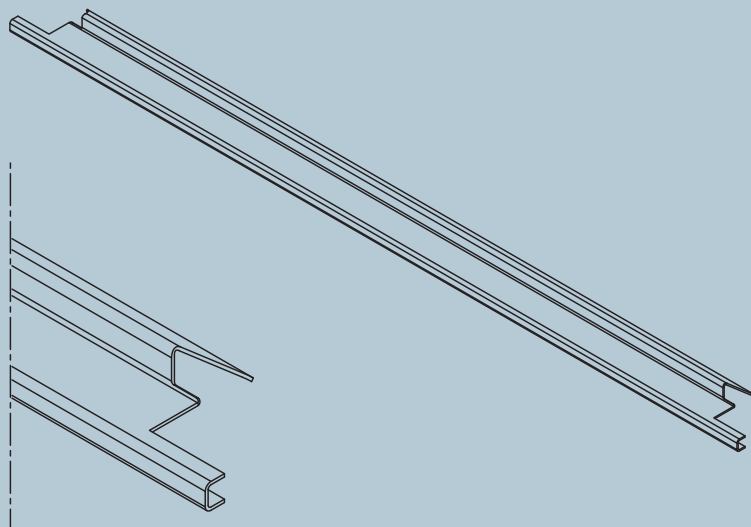
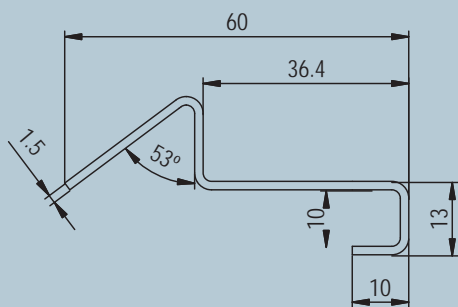

Threshold Type E

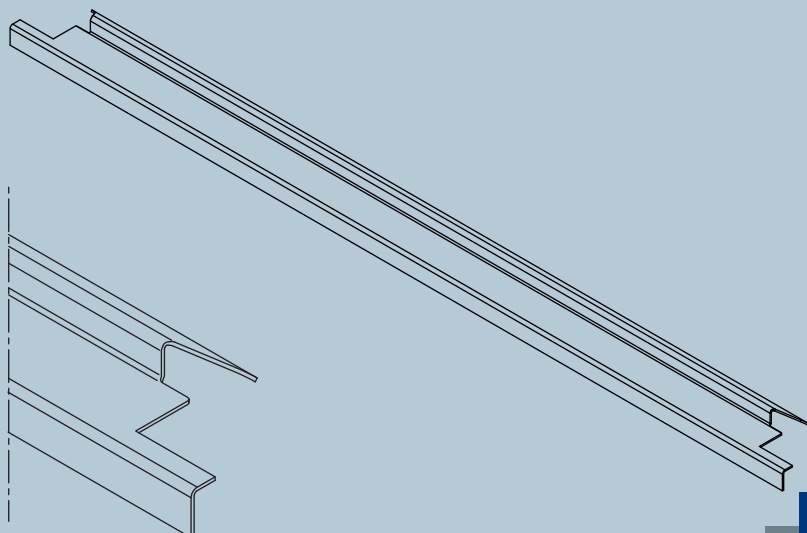
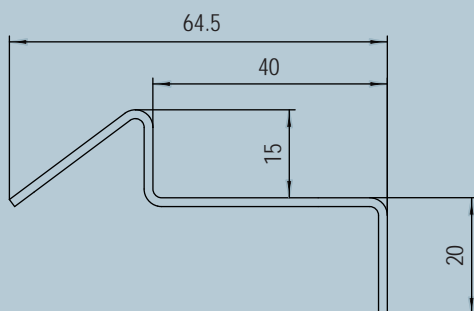

Options

Screwind System

SCREWIND SYSTEM "A"

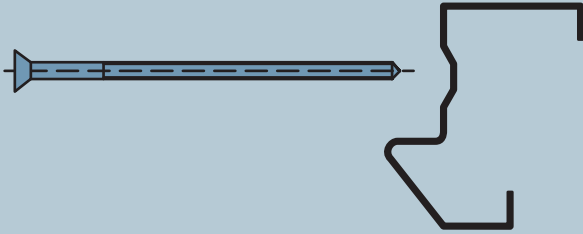

SCREWIND SYSTEM "C"

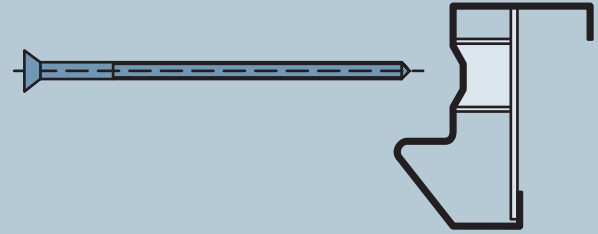

SCREWIND SYSTEM "B"

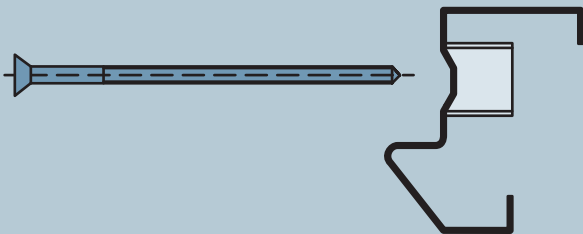

SCREWIND SYSTEM "E"

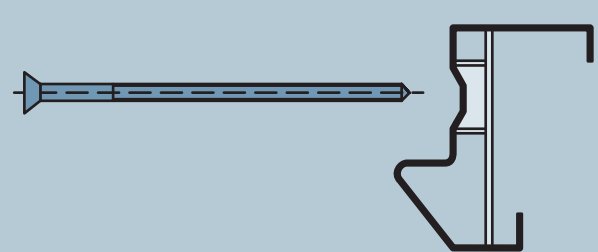

3 Points Locking System

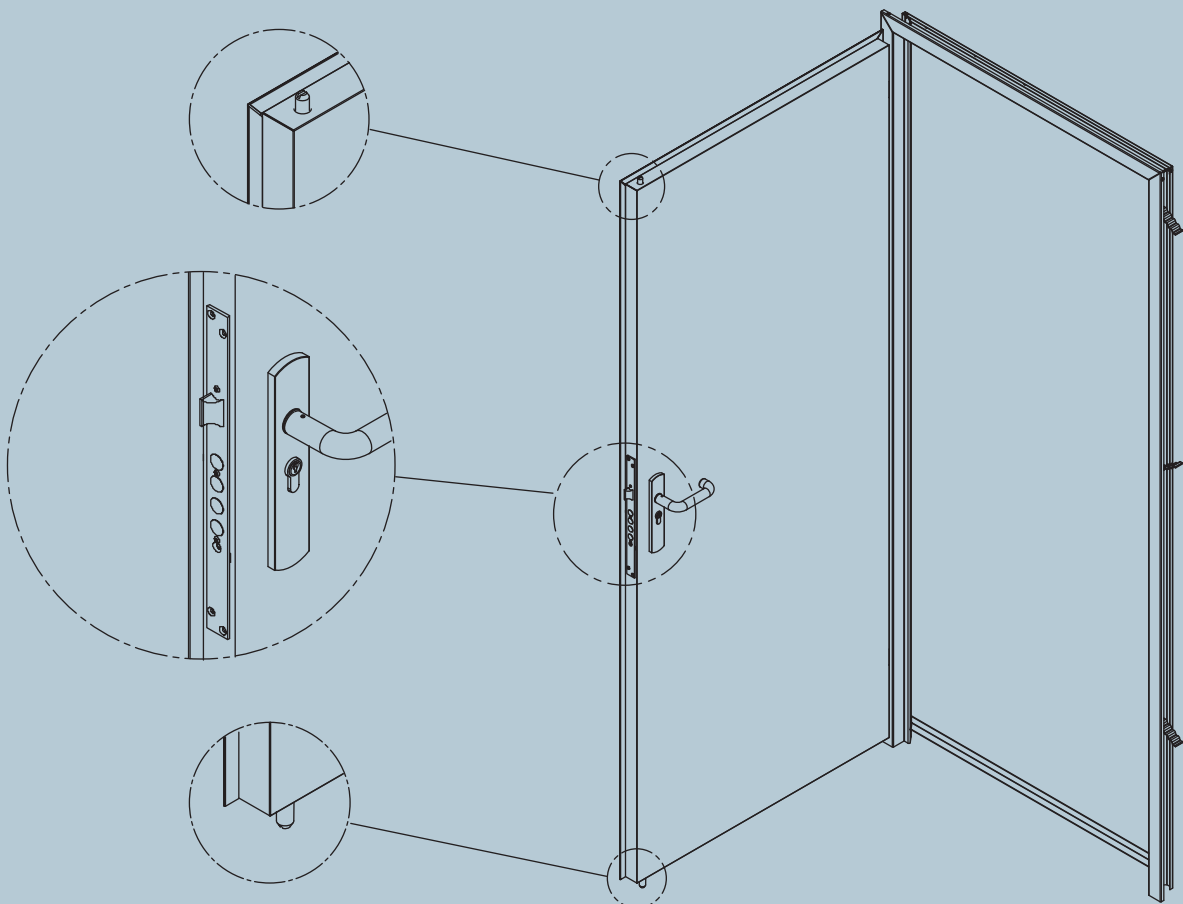

Raindrips

Raindrip Type A

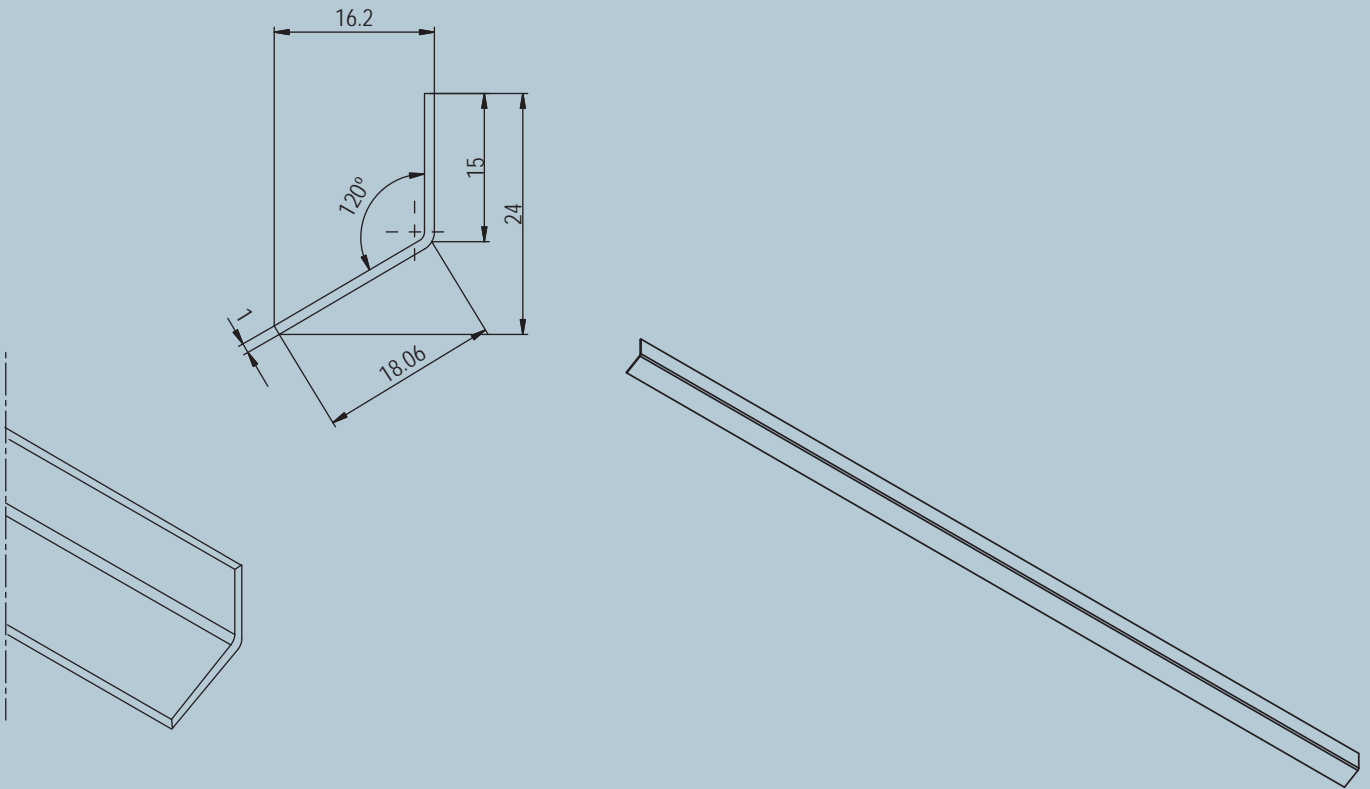

Raindrip Type B

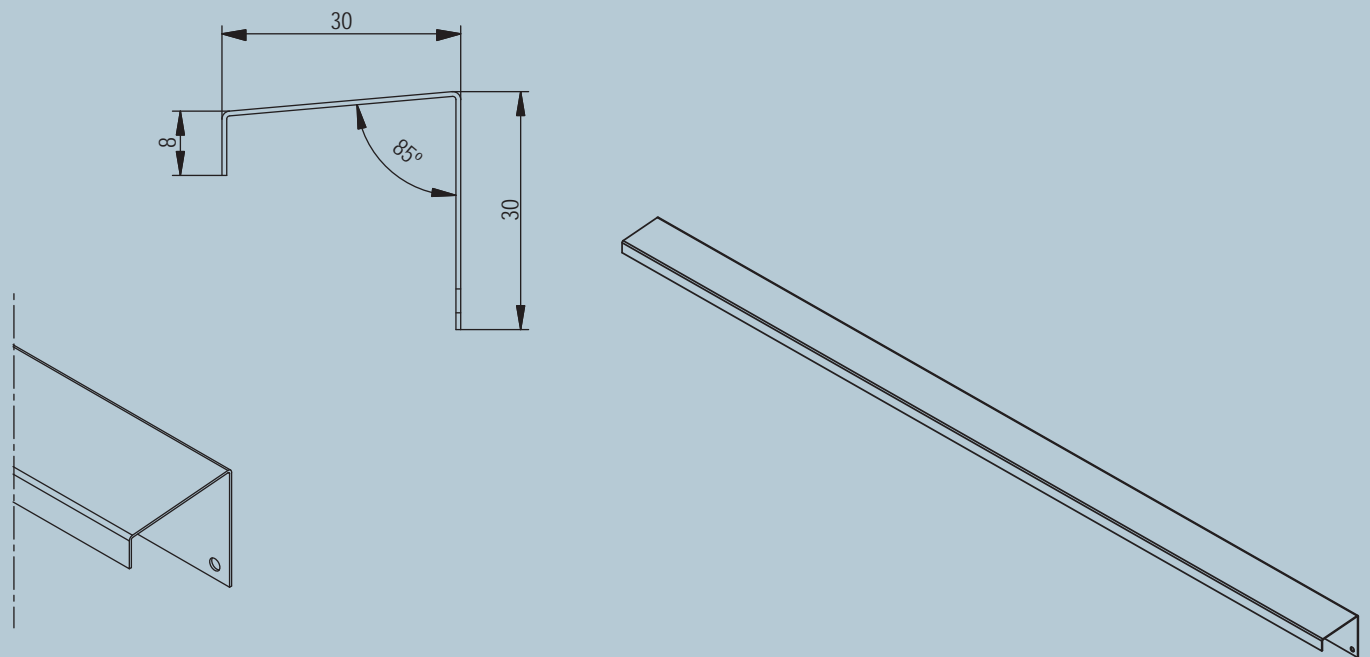

Comparison Technical Characteristics

	FINISHES					LEAF			FRAME	LOCKING SYSTEM					OTROS		
	Galvanised	Stainless Steel	White	Oak	Other Finishes	Hinges number	Embossed	Louvre	Corner	One-point lock	Lock + flush bolts	Brass cylinder	Cover plate with key-hole on both sides	Key only	Customized sizes	Extended. Stanted doors	Others materials
ENSAMBLADA SINGLE LEAF	●	●	●	●	●	2	●	●	●	●	●	●	●	●	●	●	●
ENSAMBLADA DOUBLE LEAF	●	●	●	●	●	2	●	●	●	●	●	●	●	●	●	●	●

● Yes ● No ● Optional ● Contact us

Packaging

All the multi-purpose doors are delivered in vertical palets. Packaging detail we shown below: The doors can be supplied with other packaging but always upon request.

Model	ENSAMBLADA 1 LEAF WITHOUT HEELS	ENSAMBLADA DOBLE LEAVES WITHOUT HEELS
	CS4	CS4
Number of doors	15 units	
Palet width	Total door width + 0,04 m	
Palet length	1,18 m	
Palet height	Total door height + 0,17 m	
Approx palet weight	405 kg ⁽¹⁾	787 kg ⁽²⁾

(1) Order reference 800 x 2000 Model

(2) Order reference DH 1840 x 2000 Model.

Single leaf palet
Ensamblada CS4



Double leaves palet
Ensamblada CS4



ANDREU BARBERÁ, S.L.
 Pol. Ind. Fuente del Jarro
 C/ Ciudad de Sevilla, 20
 46988 - Paterna
 Valencia - Spain
 Tel.: (+34) 96 134 32 06
 Fax: (+34) 96 134 08 59
 export@andreu.es
www.andreu.es

DISTRIBUTOR